

Project Information

Name Location: _____ / _____
 Type / Quantity: _____ / _____
 Sold to: _____
 PO#: _____

Approvals

Crossarm Details

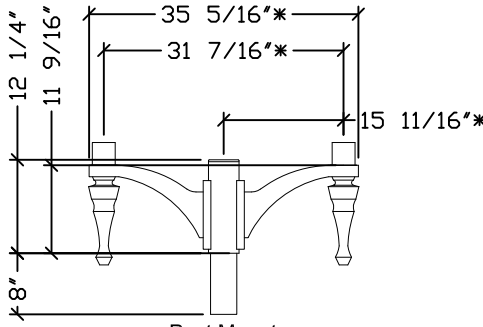

Post Mount

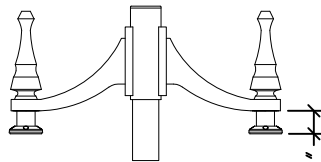

Pendant Mount

Formerly AA-351 (single) & AA-352 (twin)

*Horizontal dimensions will vary with shaft diameter

Wall Bracket Details

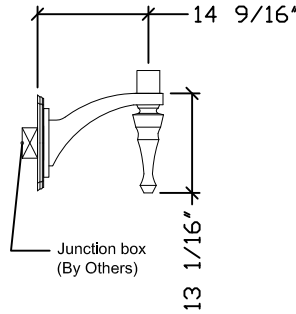

Pendant Mount

Formerly AW-351

Specifications

Construction:

All cast aluminum parts shall be low copper alloy A356. All extruded aluminum parts shall be alloy 6061-T6, 6063-T5 or equal.

Crossarm Installation:

The crossarm is designed to slip into an 8" section of the pole top and is secured with six stainless steel set screws. The pendant mounting adaptor shall be designed for 1.5G vibration conditions, when used with a Beacon Products luminaire.

Wall Bracket Installation:

The wall bracket is anchored to the wall by four mounting bolts, which are not provided by Beacon as their size (maximum diameter of 3/8"), type of fastener and depth will vary according to the type of wall. The maximum projection of the mounting bolts is 1.25". The junction box is not supplied by Beacon, however the bracket is designed to conceal a fully recessed rectangular single-gang junction box.

EPA (Effective Projected Area):

EPA is defined as (Surface Area x Drag Coefficient). Allowable Pole, Luminaire Arm, Luminaire and Accessory EPAs are derived from the most current published AASHTO standard (American Association of State Highway and Transportation Officials), currently AASHTO 2001. Customer assumes all responsibility for selecting the appropriate pole for installation. Luminaire Arm, Luminaire and Accessory EPA must be equal to or less than allowable EPA of pole. Consult a professional engineer for compliance with local codes and standards.

Pendant Luminaire Mounting Details

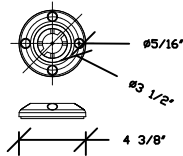

Wall Mounting Details

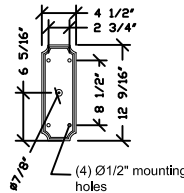

Fasteners:

All fasteners shall be stainless steel. When tamper resistant fasteners are required, spanner HD (snake eye) style shall be provided (special tool required, available at additional cost).**

Finish:

Finish shall be Beacote III polyester powdercoat electrostatically applied and thermocured. Crossarms and Wall Brackets shall be subjected to iron phosphate chemical pre-treatment prior to painting by immersion process.

Ordering Example:

AA-35 / S / 4 / B / P / BB

AA-35 / / / / / / / /

Pole Shaft profile

W Wall
 S Smooth
 F Fluted

Pole shaft Ø

W Wall
 4 4"
 5 5"
 6 6"

*Specify the above if a non-Beacon pole will be used

** Consult factory

Arrangement | EPA index (ft²) / weight (lbs)

Shaft Ø	Wall	Weight	A	B	C	D	E	F	G	H	I	J
Ø4"	EPA	-	1.14	1.88	1.88	1.51	2.11	2.11	2.11	2.11	2.62	2.62
	Weight	-	16lbs	23lbs	24lbs	23lbs	30lbs	31lbs	30lbs	37lbs	38lbs	
Ø5"	EPA	-	1.24	1.98	1.98	1.61	2.21	2.21	2.21	2.21	2.72	2.72
	Weight	-	18lbs	25lbs	26lbs	25lbs	32lbs	33lbs	32lbs	39lbs	40lbs	
Ø6"	EPA	-	1.34	2.08	2.08	1.71	2.31	2.31	2.31	2.31	2.82	2.82
	Weight	-	20lbs	27lbs	28lbs	27lbs	34lbs	35lbs	34lbs	41lbs	42lbs	

Finish

BB black
 BZ bronze
 BG green
 BW white
 BY gray
 RAL RAL-
 OTHER

Consult factory for premium and verde finishes. Custom colors available.

Luminaire Mounting

T Tenon

P Pendant